



NZ7 Automatic Transfer Switching Equipment

1. General

Applicable to the three-phase four-line two-circuit power supply network with an AC power frequency of 50Hz, rated operational voltage of AC400V, and rated operational current of up to 630A, the NZ7 series automatic transfer switching equipment can automatically connect one or several loads from one power source to another to ensure the normal power supply of the load circuit.

This product is applicable to the important places such as industrial, commercial, and storied buildings, and residential houses.

Certificate: KEMA
Execution standard: IEC/EN 60947-6-1

2. Type designation

N Z 7 - □ □ / □ □ □ □ □ □ □ □

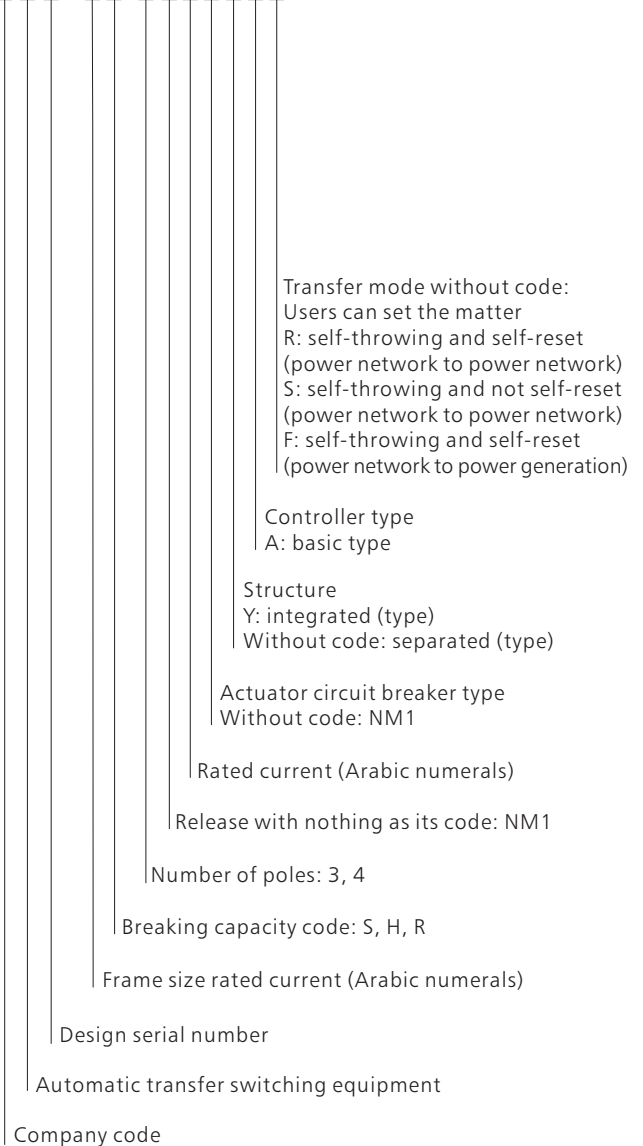

3. Operating conditions

3.1 Ambient air temperature

The upper limit for the ambient air temperature is +40°C, lower limit -5°C, and the mean value of the temperature is not greater than +35°C within 24 hours;

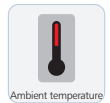

3.2 Altitude

Altitude: not higher than 2,000m for the installation site.



3.3 Atmospheric conditions:

When the ambient air temperature is +40°C, the relative humidity of the air shall not be higher than 50%, a higher relative humidity is allowed at a lower temperature, e.g. 90% at +20°C, and special measures shall be taken for the condensation occasionally produced due to temperature changes.

3.4 Class of pollution:

Class of pollution: 3



4. Technical data

Product type	NZ7-63	NZ7-125	NZ7-250	NZ7-400	NZ7-630
Up to standard	IEC/EN 60947-6-1				
Actuator circuit breaker	NM1-63	NM1-125	NM1-250	NM1-400	NM1-630
Parameters of electrical characteristics					
Operating environment temperature	-5°C~+40°C				
Altitude	2000m				
Class of pollution	3				
Specification for current	10,16,20,25, 32,40,50,63A	16,20,25,32,40, 50,63,80,100A	100,125,160, 180,200,225A	250,315, 350,400A	400,500, 630A
Rated operational voltage (Ue)	400V 50Hz				
Nominal insulation voltage (Ui)	AC500V	AC800V			
Rated impulse withstand voltage	6kV	8kV			
Number of poles	3P 4P	3P 4P	3P 4P	3P, 4P	3P, 4P
Short circuit breaking capacity codes	S H H	S H R H	S H R H	S H R H	S H R
Rated short circuit making capacity (Icm)	31.5 73.5 73.5	52.5 105 143 105	52.5 105 143 105	73.5 110 154	73.5 110 154
Rated short circuit breaking capacity (Icn)	15 35 35	25 50 65 50	25 50 65 50	35 50 70	35 50 70
Service life	6000 times	6000 times	6000 times	4000 times	3000 times
Usage category	AC-33B				
Electric equipment grade	CB Class				
Protection level	IP30 (except the main circuit terminal)				
Protection	Overload protection/short circuit protection				
Controller characteristic					
Controller	Type A(basic type)				
Rated control supply voltage Us	230V 50Hz				
Installation mode for the controller	Integrated/separated (as installed on the surface of the cabinet)				
Operating transfer time (no time delay)	≤3.2s	≤3.5s	≤3.6s	≤4s	≤5s
Power consumption	≤10W				
Installation and connection					
Installation mode	Fixed type				
Connection mode	Front connection				

5. Characteristics and functions

The NZ7 series automatic transfer switching equipment (hereinafter referred to as automatic transfer switch) is the CB class product of a new generation combined with the advanced digital electronic control technique. The product features compactness, energy conservation, convenient installation, reliable dual-interlock protection, etc., and is advanced and complete in terms of function.

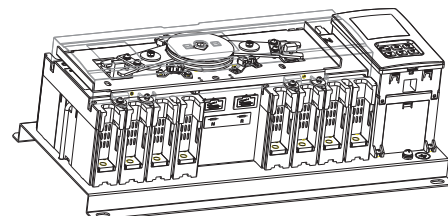

Single motor structure, compact

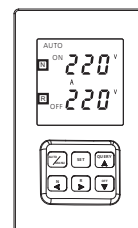

Visualized management

5.1 Compactness

The transfer function is achieved via using the forward and backward rotation of the only one motor which allows for reducing the product's height and room for its installation.

5.2 Energy saving

The driving mechanism works in the mode of motor drive with less power consumption and noise.

Type A controller (long-term service)	Transmission mechanism (short-term service)		
	Type 63/Type 100	Type 225	Type 400/Type 630
≤10W	20W	40W	20W

5.3 Advanced and multipurpose functions

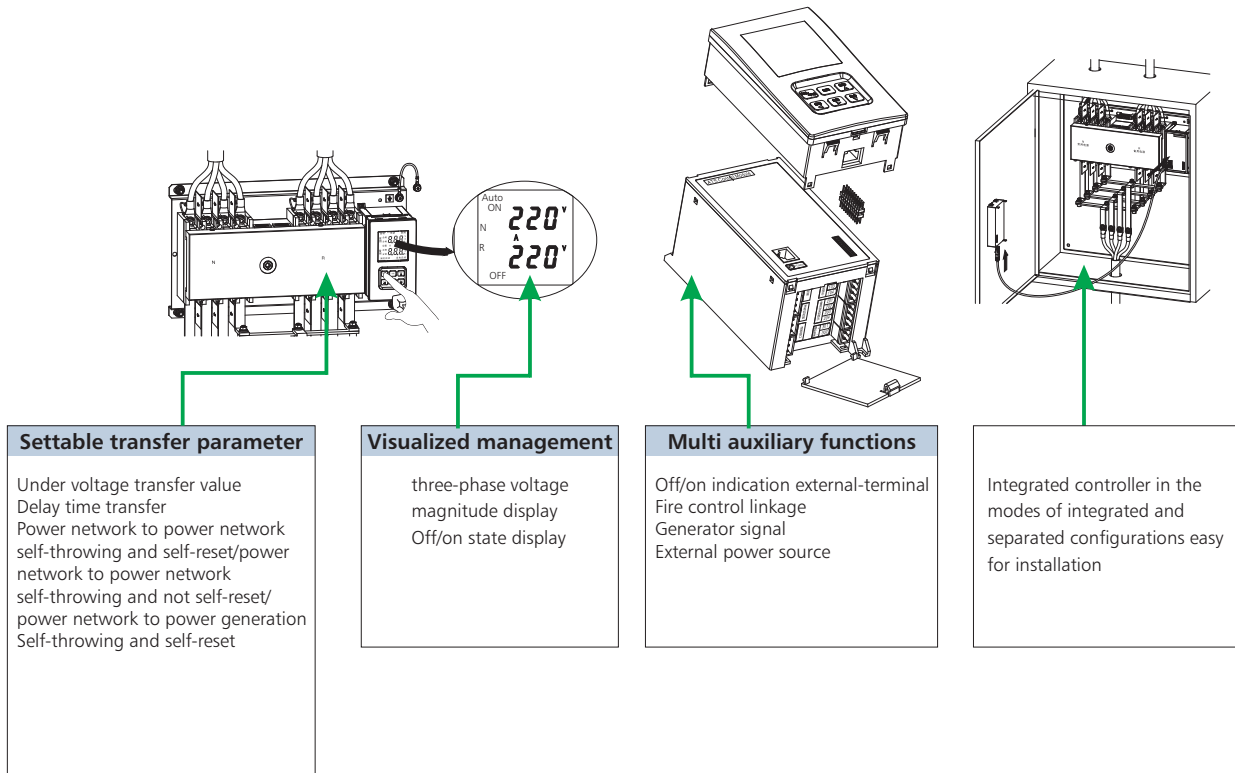

5.4 Dual-interlock protection

The mechanical-electrical interlock duplex protection is used to prevent two power sources from being connected simultaneously to the load, wherein the electrical interlock works in the breaker contact position mode for directly indicating the automatic transfer switch to perform the genuine electrical interlock so that the automatic transfer does not take place automatically in such cases as contact fusion welding, breaker handle damage, and circuit fault breaker tripping.

6. Controller

Type and function	Type A (basic type)
Modes of manual and automatic transfer	■
Working position of the main contact (actuator circuit breaker)	
Prime power turned on	■
Standby power turned on	■
OFF	■
Automatic control	
Monitoring the prime power	Failures such as loss of phase/voltage, under and over voltage for any of three phases of the power supply
Monitoring the standby power	Failures such as loss of phase/voltage, under and over voltage for any of three phases of the power supply
Self-throwing and self-reset	■
Self-throwing and not self-reset	■
Power network to power network	■
Power network to power generation	■
No-voltage transfer	■
Under voltage transfer	■
Over voltage transfer	■
Adjustable delay time	■
Transfer delay a	Continuously adjustable in the range of 0s~180s
Return c	Continuously adjustable in the range of 0s~180s
Generator control	■
Fire control linkage (inactive contact)	■
Indication	
Indication for on, off, and double-break	■
Prime power indication	■ (Displaying voltage magnitude)
Standby power indication	■ (Displaying voltage magnitude)
Fault tripping indication	■
External indication signal terminal	■
Parameter setting indication	■
Interlock protection	
Mechanical interlock	■
Electrical interlock	■ (not transfer automatically with faulty tripping)

6.1 The Type A integrated controller works in the modes of integrated or separated configurations, and is installed in the cabinet or on the panel to allow operation outside the cabinet.

Whether to transfer from one power source to another depends on the state of the operational power supply.

Generating set control

Press-key manually forced transfer operating

6.2 Control voltage

AC230V 50Hz

6.3 Operation: automatic operation, manual operation

6.4 Setting delay

Transfer delay: adjustable in the range of 0s - 180s, prime power failure, time before off for QN

Return delay: continuously adjustable within the range of 0s - 180s, prime power recovery, time before off for QR

6.5 Interface for display and operation
LED digital display

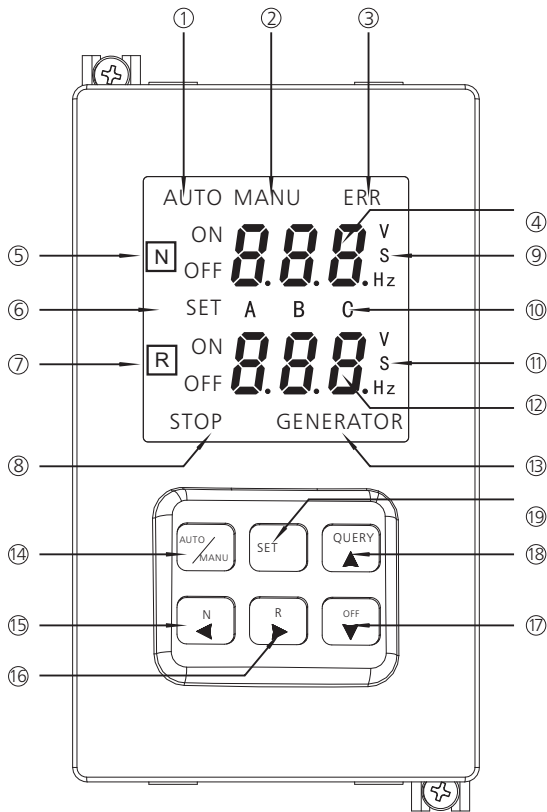

1. Indication of automatic working mode;
2. Indication of manual working mode;
3. Failure indication
When the breaker is disengaged due to the failure or short-circuit of the switch, this lamp will be on;
4. Display area of normal power voltage parameters
It displays normal power voltage parameters and changeover delay time under the working condition, and setting items under the setting condition;
5. Indication of the on or off of breaker on the normal power side
6. Indication of setting condition
7. Indication of the on or off of breaker on the alternative power side
8. Indication of the start of stop function;
9. Units of voltage, time, and frequency of the normal power;
10. Phases A, B, and C;
11. Units of voltage, time, and frequency of the alternative power;
12. Display area of alternative power voltage parameters;
It displays alternative power voltage parameters and transfer delay time under the working condition, and setting items under the setting condition;
13. Indication of the start signal of generator
14. Selection button of automatic/manual transfer
When it is regularly used, it can be used for selecting the automatic or manual mode; it saves and exits the functions when it is under the setting condition.
15. Button for compulsorily turn off the normal power
Under the manual control mode, if this button is pressed, it can compulsorily switch to the normal power; if it is setting condition, this button is the "scroll up" button of setting programs;
16. Button for compulsorily turn off the alternative power
Under the manual control mode, if this button is pressed, it can compulsorily switch to the alternative power; if it is setting condition, this button is the "scroll up" button of setting programs;
17. Off button
Under the manual control mode, if either line of both power lines are normal and this button is pressed, it will switch to the disengagement position; this button is the minus button for setting parameters when it is under setting condition;
18. Failure inquiry button
When the switch fails and malfunction lamp on the failure screen is on, the detail malfunction code can be inquired if it is pressed; this button is the plus button if it is under the setting condition;
19. Setting button
When this button is pressed, it may enter into the parameter setting menu of the controller.

6.6 Operation description on parameter setting

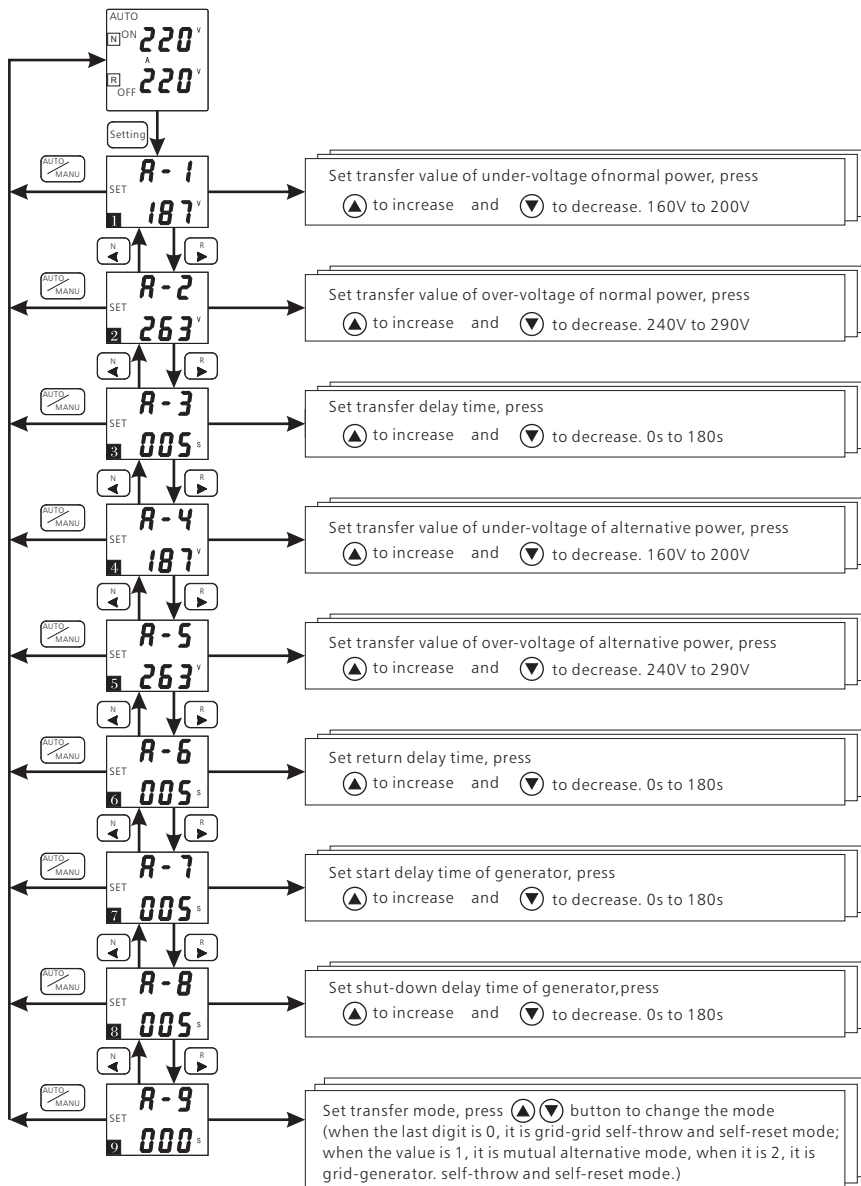

Note for keys

Button Description:

Press the Setting Button when the controller is working, LED will display the parameter setting menu interface displayed in Figure ; press “◀” and “▶” buttons in the setting menu to scroll up the setting options; if the automatic/ manual button is pressed, it will exit the setting menu; press “▼” or “▲” to change parameters.



Working processes of typy A controller

Grid – Grid
self-throw and self-reset operation

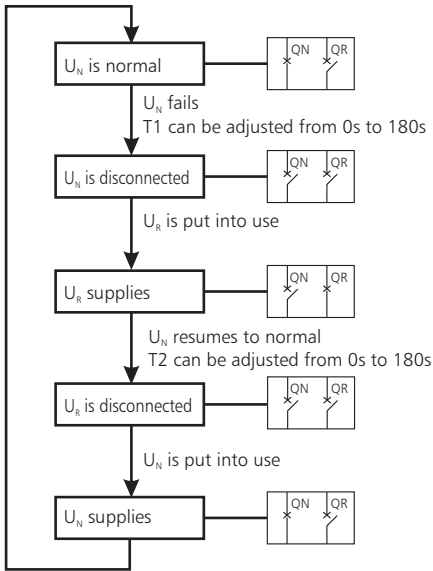

Grid – Grid
mutual alternative operation

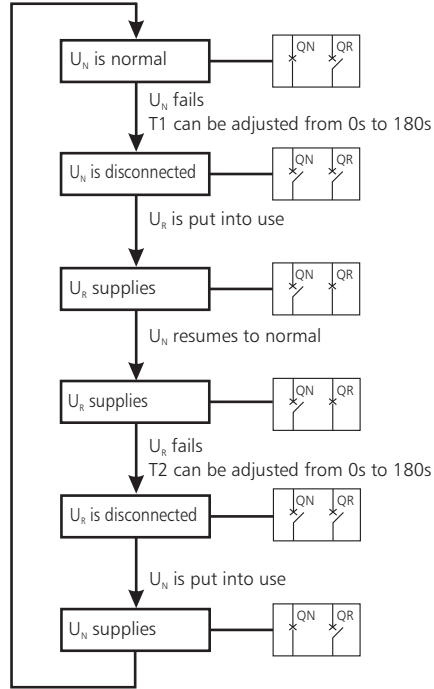

Grid-Power Generation
self-throw and self-reset operation

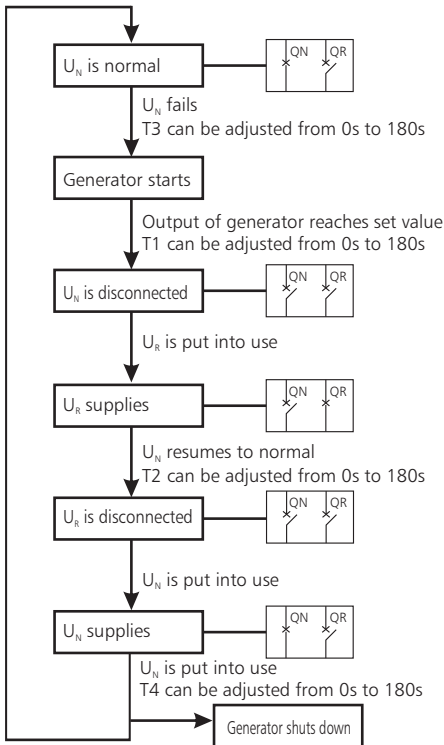

- T1: Transfer delay can be adjusted from 0s to 180s
Failure of UN , time before disconnecting QN
- T2: Return delay time can be adjusted from 0s to 180s
Normal of UN , time before disconnecting QR
- T3: Delay time in starting generator can be adjusted from 0s to 180s

- T4: Delay time in shutting-down generator can be adjusted from 0s to 180s
- QN: Operating breaker on the frequently used side
- QR: Operating breaker on the stand-by side
- UN : Normal power supply
- UR : Alternative power supply

7. N27 external connection diagram

7.1 product connection diagram

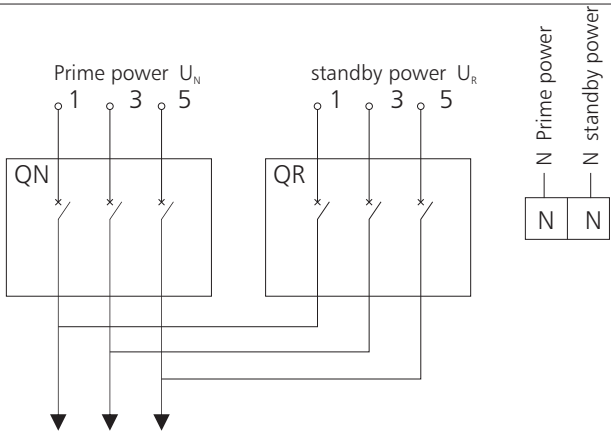

7.2 4P product connection diagram

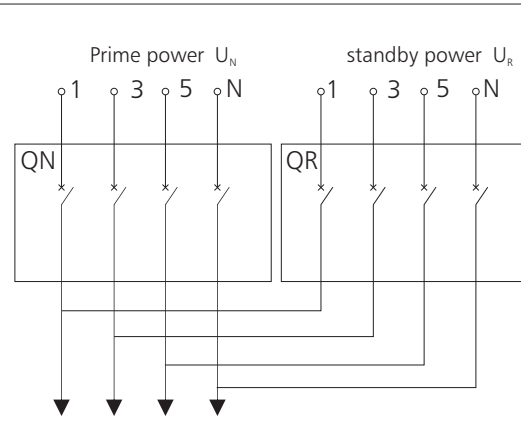

Note :

QN actuator circuit breaker on the prime (normal) side
QR actuator circuit breaker on the standby (reserve) side

7.3 Wiring diagram of external terminals of the controller

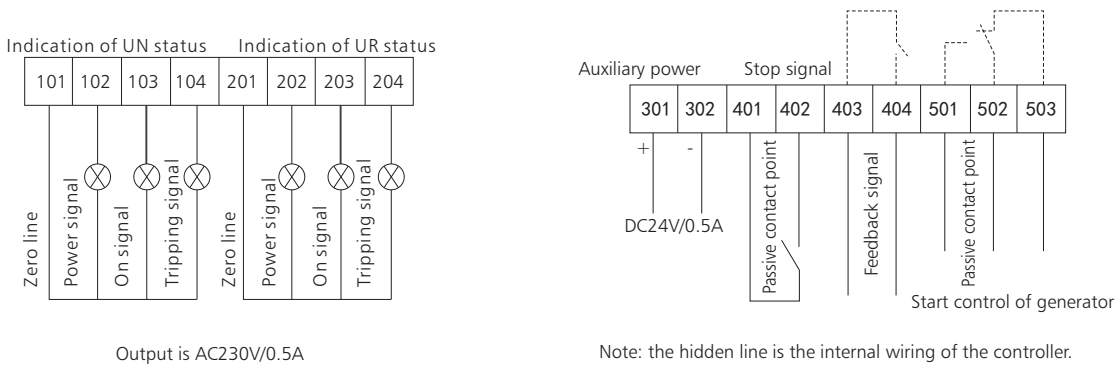

7.4 Application

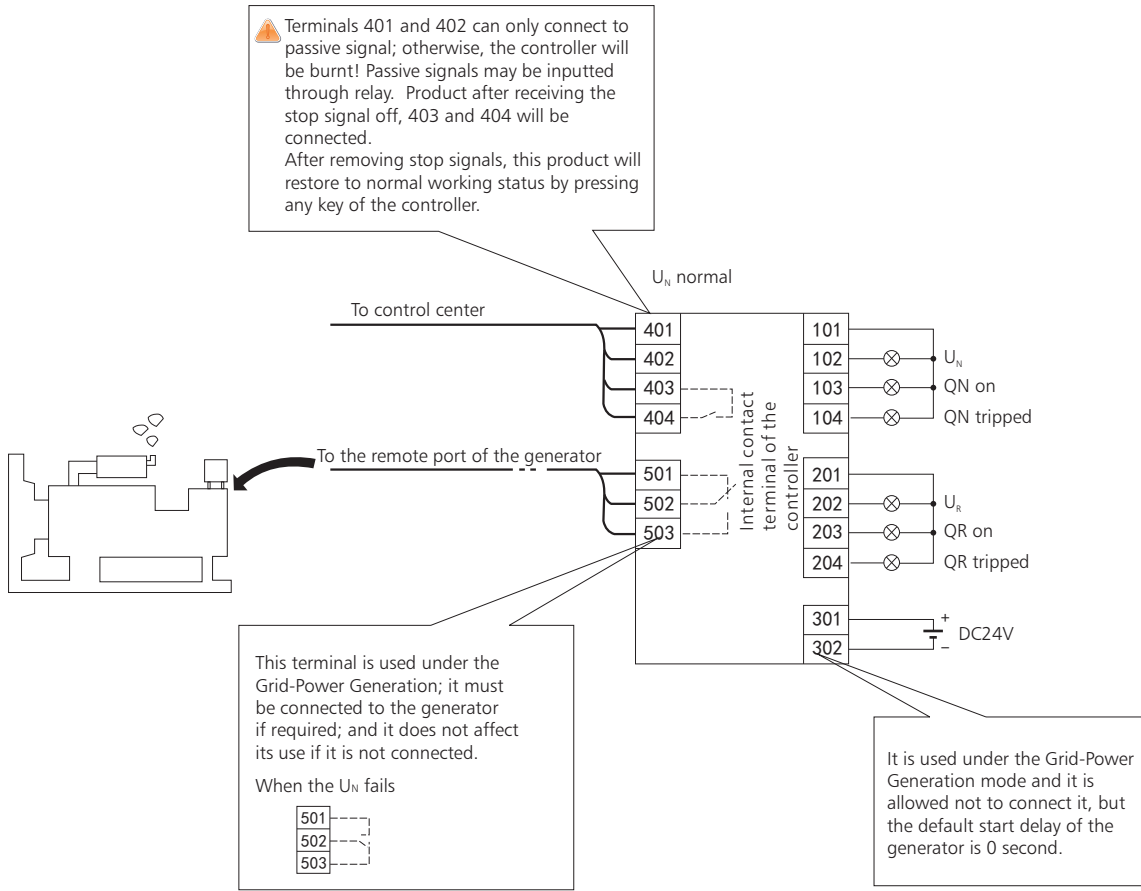

8. Line incoming pattern

8.1 Connecting bus-bar type

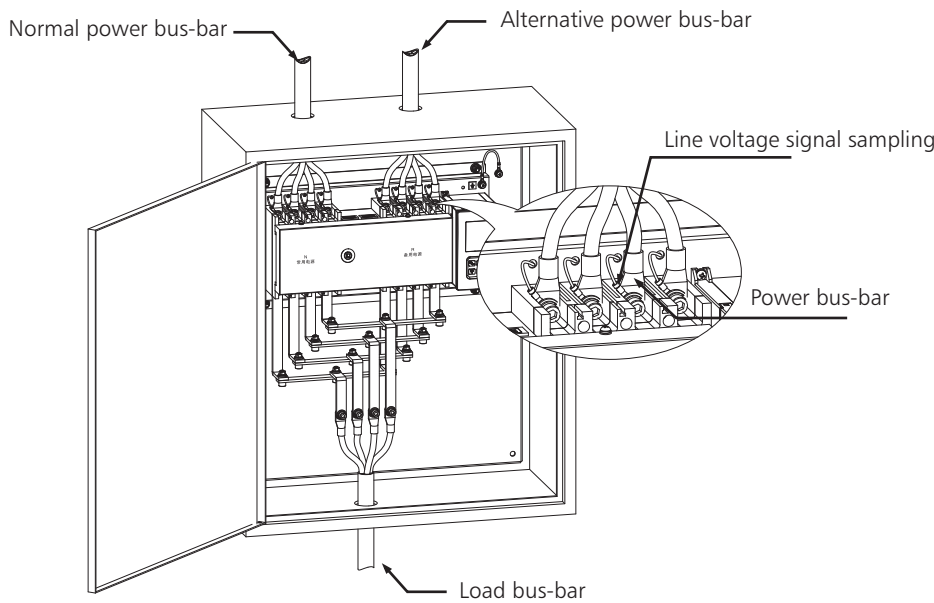

8.2 Installation mode: vertical installation or horizontal installation

9. Overall and mounting dimensions (mm)

9.1 Outline dimension & Installation dimension

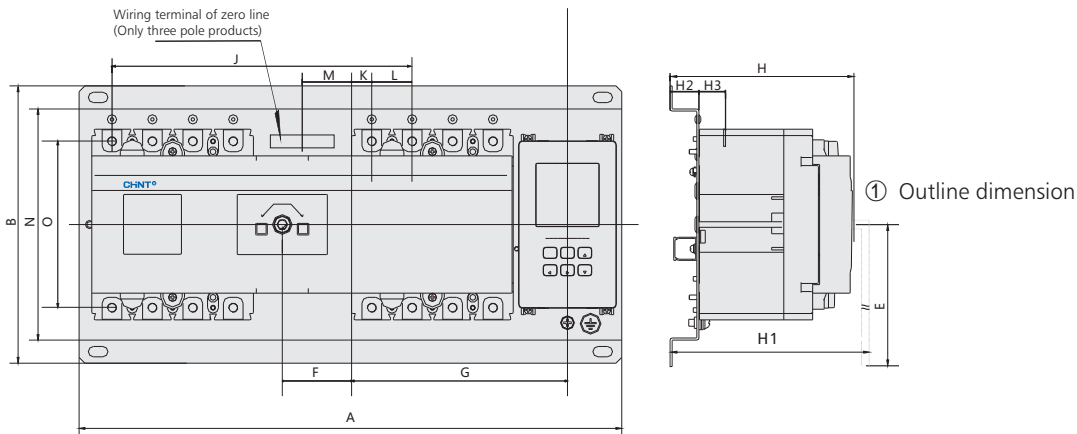

Dimension Modle	A		B	E	F		G		J	K		L	M	N	O	H	H1	H2	H3
	3P	4P			3P	4P	3P	4P		3P	4P								
NZ7-63	355	380	240	200	40	52.5	132.5	145	178	24	11.5	25	40	200	117	150	170	25	18/28
NZ7-125	390	420	240	200	43	58	148	163	194	24	9	30	43	200	136	150	180	25	24
NZ7-250	435	470	240	200	41.5	59	170.5	188	225	36	18.5	35	41.5	200	144	160	190	25	24
NZ7-400	565	615	330	225	43.5	68.5	232.5	257.5	304	61.5	36.5	48	43.5	265	224	200	227	24	40
NZ7-630	680	740	330	225	45.5	74.5	291	320	385	89	60	58	45.5	270	234	200	232	24	42

9.2 Installation dimension

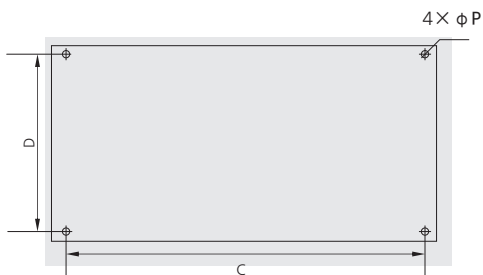

Dimension Modle	C		D	P
	3P	4P		
NZ7-63	322	347	220	φ 8
NZ7-100	357	387	220	φ 8
NZ7-225	402	437	220	φ 8
NZ7-400	505	555	300	φ 10
NZ7-630	622	680	300	φ 10

9.3 Controller Module

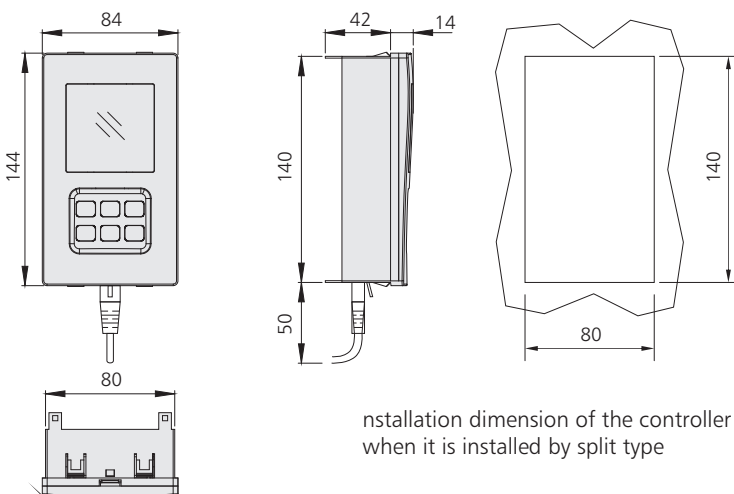

Installation dimension of the controller when it is installed by split type

10. Ordering information

The user shall indicate such items as the type, current specification, number of poles.
Example: If you order an auto transfer switch equipment, shell current 100A, rated current 100A, breaking capacity of Type H, 4 poles, Type A controller, you can write it as NZ7-100H/4100YA.

