

Contactors, Relays, Starters

Starters



NS2
Manual Motor Starter

Page F-01



NQ2
Direct On-line Starter

Page F-10



NQ3
DOL
Electromagnetic
Starter

Page F-15



NS2 Manual Motor Starter

1. General

- 1.1 Certificates: CE, ESC, UkrSEPRO, GOST, RCC, UL;
- 1.2 Electric ratings: AC690V, 25A, 80A;
- 1.3 Standard: IEC/EN 60947-2, IEC60947-4-1

2. Type designation

NS2 - □ □ / □

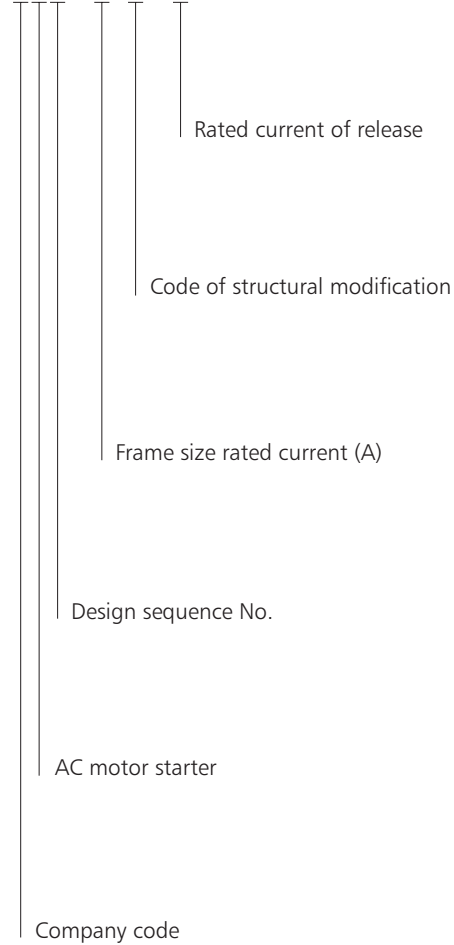

3. Operating conditions

- 3.1 Temperature: $-5^{\circ}\text{C} \sim +40^{\circ}\text{C}$,
average temperature in 24 hours not exceed $+35^{\circ}\text{C}$
- 3.2 Altitude: not exceed 2000m
- 3.3 Air conditions:
At mounting site, relative humidity not exceed 50% at the max temperature of $+40^{\circ}\text{C}$, higher relative humidity is allowable under lower temperature, for example, RH could be 90% at $+20^{\circ}\text{C}$
- 3.4 Pollution grade: Grade III
- 3.5 Release grade:
10A(NS2-25, NS2-25X)
10 (NS2-80B)
- 3.6 Rated operational system:
Continuous operational system
- 3.7 Mounting conditions:
The inclination between the mounting plane and the vertical plane shall not exceed 5°
The product shall be installed and operated at a place without obvious shake, impact and vibration.



4. Technical data

4.1 Protection properties

Over-load Protection Properties

Series No.	Multiple of setting current	Initial status	Time		Expected results	Ambient temperature
1	1.05	Cold status	$t \geq 2h$		Non-tripping	$+20^{\circ}\text{C} \pm 2^{\circ}\text{C}$
2	1.20	Heat status (right after test.1)	$t < 2h$		Tripping	$+20^{\circ}\text{C} \pm 2^{\circ}\text{C}$
3	1.50	Heat status (right after test.1)	Tripping class	10A $t < 2\text{min}$	Tripping	$+20^{\circ}\text{C} \pm 2^{\circ}\text{C}$
		10 $t < 4\text{min}$				
4	7.20	Cold status	Tripping class	10A $2s < t \leq 10s$	Tripping	$+20^{\circ}\text{C} \pm 2^{\circ}\text{C}$
		10 $4s < t \leq 10s$				

Phase failure protection properties

Series No.	Multiple of setting current		Initial status	Time	Expected results	Ambient temperature
	Any 2 phase	The other phase				
1	1.0	0.9	Cold status	$t \geq 2h$	Non-tripping	$+20^{\circ}\text{C} \pm 2^{\circ}\text{C}$
2	1.15	0	Heat status (right after test.1)	$t < 2h$	Tripping	$+20^{\circ}\text{C} \pm 2^{\circ}\text{C}$

Temperature compensation properties

Series No.	Multiple of setting current	Initial status	Time	Expected results	Ambient temperature
1	1.0	Cold status	$t \geq 2h$	Non-tripping	$+40^{\circ}\text{C} \pm 2^{\circ}\text{C}$
2	1.2	Heat status (right after test.1)	$t < 2h$	Tripping	$+40^{\circ}\text{C} \pm 2^{\circ}\text{C}$
3	1.05	Cold status	$t \geq 2h$	Non-tripping	$-5^{\circ}\text{C} \pm 2^{\circ}\text{C}$
4	1.3	Heat status (right after test.3)	$t < 2h$	Tripping	$-5^{\circ}\text{C} \pm 2^{\circ}\text{C}$



4.2 Technical parameters

Model			NS2-25, NS2-25X			
Picture						
Rated insulation voltage $U_i(V)$			690			
Rated operational voltage $U_e(V)$			230/240, 400/415, 440, 500, 690			
Rated impulse withstand voltage $U_{imp}(V)$			8000			
Regulating rang of setting current (A)			0.1~0.16	0.16~0.25	0.25~0.4	0.4~0.63
Rated current of release			0.16	0.25	0.4	0.63
Rated ultimate short-circuit breaking capacity $I_{cu}(kA)$	230/240V		100	100	100	100
	400/415V		100	100	100	100
	440V		100	100	100	100
	480/500V		100	100	100	100
	660/690V		100	100	100	100
Rated service short-circuit breaking capacity $I_{cs}(kA)$	230/240V		100	100	100	100
	400/415V		100	100	100	100
	440V		100	100	100	100
	480/500V		100	100	100	100
	660/690V		100	100	100	100
Arcing distance (mm)			40	40	40	40
Standard rated power of three-phase motor (kW)	230/240V		-	-	-	-
	400V		-	-	-	-
	415V		-	-	-	-
	440V		-	-	-	-
	500V		-	-	-	-
	660/690V		-	-	-	0.37
Current setting value of instantaneous electromagnetic release $I_r(A)$			1.5	2.4	5	8
Current rating of fuse-link of back-up fuse, which is only needed in case of $I_{cc} > I_{cu}$ (I_{cc} : prospective short-circuit breaking current)	230/240V	aM A	★	★	★	★
		gI/gG A	★	★	★	★
	400/415V	aM A	★	★	★	★
		gI/gG A	★	★	★	★
	440V	aM A	★	★	★	★
		gI/gG A	★	★	★	★
	500V	aM A	★	★	★	★
		gI/gG A	★	★	★	★
★: fuse is not required	690V	aM A	★	★	★	★
		gI/gG A	★	★	★	★
Degree of protection			IP2L0	IP2L0	IP2L0	IP2L0

NS2-25, NS2-25X



690

230/240, 400/415, 440, 500, 690

8000

0.63~1	1~1.6	1.6~2.5	2.5~4	4~6.3	6~10
1	1.6	2.5	4	6.3	10
100	100	100	100	100	100
100	100	100	100	100	100
100	100	100	100	50	15
100	100	100	100	50	10
100	100	3	3	3	3
100	100	100	100	100	100
100	100	100	100	100	100
100	100	100	100	50	15
100	100	100	100	50	10
100	100	2.25	2.25	2.25	2.25
40	40	40	40	40	40
-	-	0.37	0.75	1.1	2.2
-	0.37	0.75	1.5	2.2	4
-	-	0.75	1.5	2.2	4
0.37	0.55	1.1	1.5	3	4
0.37	0.75	1.1	2.2	3.7	5.5
0.55	1.1	1.5	3	4	7.5
13	22.5	33.5	51	78	138
★	★	★	★	★	★
★	★	★	★	★	★
★	★	★	★	★	★
★	★	★	★	★	★
★	★	★	★	50	50
★	★	★	★	63	63
★	★	★	★	50	50
★	★	★	★	63	63
★	★	16	25	32	32
★	★	20	32	40	40
IP2L0	IP2L0	IP2L0	IP2L0	IP2L0	IP2L0

F

4.3 Technical parameters

Model			NS2-25, NS2-25X			
Picture						
Rated insulation voltage U_i (V)			690			
Rated operational voltage U_e (V)			230/240, 400/415, 440, 500, 690			
Rated impulse withstand voltage U_{imp} (V)			8000			
Regulating rang of setting current (A)			9~14	13~18	17~23	20~25
Rated current of release			14	18	23	25
Rated ultimate short-circuit breaking capacity I_{cu} (kA)	230/240V		100	100	50	50
	400/415V		15	15	15	15
	440V		8	8	6	6
	480/500V		6	6	4	4
	660/690V		3	3	3	3
Rated service short-circuit breaking capacity I_{cs} (kA)	230/240V		100	100	50	50
	400/415V		7.5	7.5	6	6
	440V		4	4	3	3
	500V		4.5	4.5	3	3
	660/690V		2.25	2.25	2.25	2.25
Arcing distance (mm)			40	40	40	40
Standard rated power of three-phase motor (kW)	230/240V		3	4	5.5	5.5
	400V		5.5	7.5	11	11
	415V		5.5	9	11	11
	440V		7.5	9	11	11
	500V		7.5	9	11	15
Current setting value of instantaneous electromagnetic release I_r (A)			170	223	327	327
Current rating of fuse-link of back-up fuse, which is only needed in case of $I_{cc} > I_{cu}$ (I_{cc} : prospective short-circuit breaking current)	230/240V	aM A	★	★	80	80
		gI/gG A	★	★	100	100
	400/415V	aM A	63	63	80	80
		gI/gG A	80	80	100	100
	440V	aM A	50	50	63	63
		gI/gG A	63	63	80	80
	500V	aM A	50	50	50	50
		gI/gG A	63	63	63	63
★: fuse is not required	690V	aM A	40	40	40	40
		gI/gG A	50	50	50	50
Degree of Protection			IP2L0	IP2L0	IP2L0	IP2L0

NS2-80B



690

230/240, 400/415

8000

	16~25	25~40	40~63	56~80
	25	40	63	80
	-	-	-	-
	15	15	15	15
	-	-	-	-
	-	-	-	-
	-	-	-	-
	7.5	7.5	7.5	7.5
	-	-	-	-
	-	-	-	-
	-	-	-	-
	50	50	50	50
	5.5	11	15	22
	11	18.5	30	40
	11	22	33	45
	-	-	-	-
	-	-	-	-
	-	-	-	-
	327	480	756	960
	★	★	★	★
	★	★	★	★
	250	250	315	315
	315	315	400	400
	-	-	-	-
	-	-	-	-
	-	-	-	-
	-	-	-	-
	-	-	-	-
	-	-	-	-
	IP2L0	IP2L0	IP2L0	IP2L0

F

5. Accessories

5.1 Under-voltage release



Rated insulation voltage $U_i(V)$	Voltage range of operation	Model	Specification
690	35%~70% U_e	NS2-UV110	110~115V 50Hz
690	35%~70% U_e	NS2-UV110	127V 60Hz
690	35%~70% U_e	NS2-UV220	220~240V 50Hz
690	35%~70% U_e	NS2-UV380	380~400V 50Hz
690	35%~70% U_e	NS2-UV380	440V 60Hz

5.2 Shunt release



Rated insulation voltage $U_i(V)$	Voltage range of operation	Model	Specification
690	70%~110% U_e	NS2-SH110	110~115V 50Hz
690	70%~110% U_e	NS2-SH110	127V 60Hz
690	70%~110% U_e	NS2-SH220	220~240V 50Hz
690	70%~110% U_e	NS2-SH380	380~400V 50Hz
690	70%~110% U_e	NS2-SH380	440V 60Hz

5.3 Instantaneous auxiliary contact

5.3.1 NS2-AE20, NS2-AE11



Rated insulation voltage $U_i(V)$	Conventional heating current $I_{th}(A)$	Model	Configuration
250	2.5	NS2-AE20	2N/O
250	2.5	NS2-AE11	1N/O+1N/C

Application class, rated operational voltage and tated operational current of instantaneous auxiliary contact

Utilization category	AC-15				DC-13		
	Rated operational voltage $U_e(V)$	24	48	110/127	230/240	24	48
Rated operational current $I_e(A)$	2	1.25	1	0.5	1	0.3	0.15
Normal operational power $P(W)$	48	60	127	120	24	15	9

5.3.2 NS2-AU20, NS2-AU11



Rated insulation voltage $U_i(V)$	Conventional heating current $I_{th}(A)$	Model	Configuration
690	6	NS2-AU20	2N/O
690	6	NS2-AU11	1N/O+1N/C

Note: NS2-80B temporarily only has NS2-AU auxiliary contact, which is for NS2-80B special use.

Application class, rated operational voltage and rated operational current of instantaneous auxiliary contact

Utilization category	AC-15						
	Rated operational voltage $U_e(V)$	48	110/127	230/240	380/415	440	500
Rated operational current $I_e(A)$	6	4.5	3.3	2.2	1.5	1	0.6
Normal operational power $P(W)$	300	500	720	850	650	500	400

Utilization category	DC-13				
	Rated operational voltage $U_e(V)$	24	48	60	110
Rated operational current $I_e(A)$	6	5	3	1.3	0.5
Normal operational power $P(W)$	140	240	180	140	120

5.4 Fault signal contact and instantaneous auxiliary contact

	Rated insulation voltage $U_i(V)$	Conventional heating current $I_{th}(A)$		Model	Configuration
		Instantaneous auxiliary contact	Fault signal contact		
	690	6	2.5	NS2-FA0110	1N/C+1N/O
	690	6	2.5	NS2-FA0101	1N/C+1N/C
690	6	2.5	NSE-FA1010	1N/O+1N/O	
690	6	2.5	NS2-FA1001	1N/O+1N/C	

Application class, rated working voltage and rated operational current of fault signal contact

Application class	AC-14				DC-13		
Rated operational voltage $U_e(V)$	24	48	110/127	230/240	24	48	60
Rated operational current $I_e(A)$	1.5	1	0.5	0.3	1	0.3	0.15
Normal operational power $P(W)$	36	48	72	72	24	15	9
Operation features (times)	1000	1000	1000	1000	1000	1000	1000

Capacity of abnormal connection and disconnection of fault signal contact and insrantaneous auxiliary contact

Utilization category	Connection			Disconnection			Number of on/off operation cycles and operation frequency		
	I/I_e	U/U_e	$\cos \phi$ or $t0.95$	I/I_e	U/U_e	$\cos \phi$ or $t0.95$	Number of operation cycles	Number of operation cycles per min.	On power time
AC-14	6	1.1	0.7	6	1.1	0.7	10	2	0.05
AC-15	10	1.1	0.3	10	1.1	0.3	10	2	0.05
DC-13	1.1	1.1	6Pe	1.1	1.1	6Pe	10	2	0.05

Note: $Pe \geq 50W$, upper limit of $T0.95 \approx 6 Pe \leq 300ms$.

5.5 Installation box for NS2-25

	NS2-MC Installation box without pushbutton	IP55
	NS2-MC01 Installation box with emergency pushbutton	IP55

6. Overall and mounting dimension (mm)

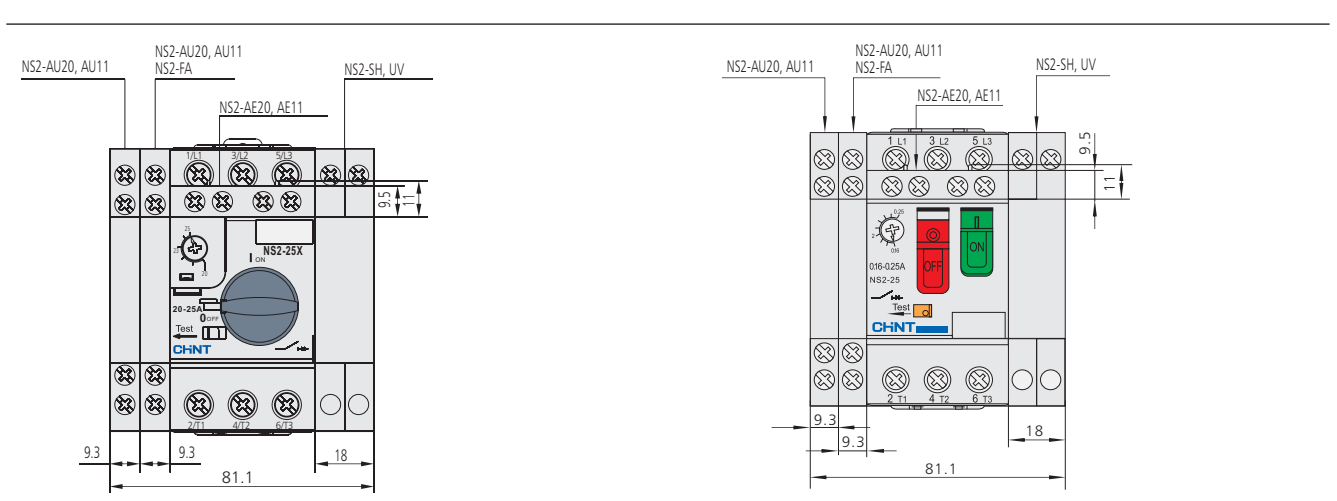

NS2-25X

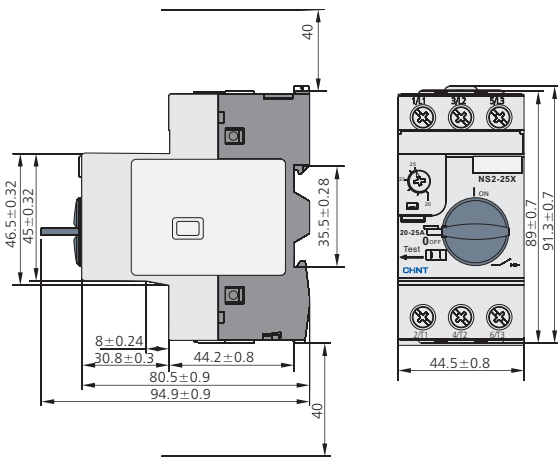

NS2-25

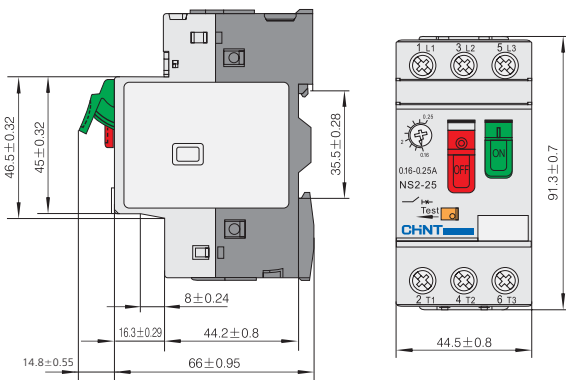

NS2-80B

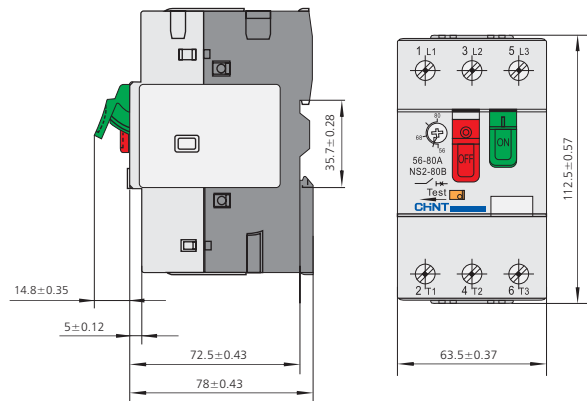

NS2-MC

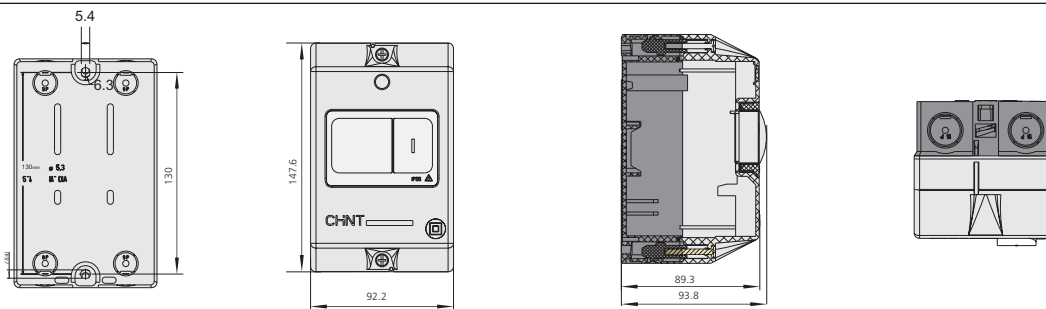

NS2-MC01

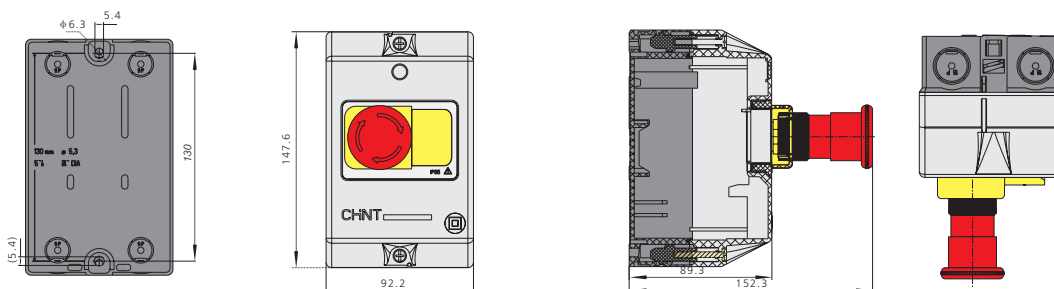



NQ2 Direct On-line Starter

1. General

- 1.1 NQ2 series electromagnetic starter ("starter" for short hereinafter) applies mainly to circuit with AC current of 50Hz (or 60Hz), rated operational voltage of 660V and rated controlled power up to 33kW (current up to 68A) for using to control the direct start and halt of the electromotor to protect the motor from overload and phase failure.
- 1.2 The starter conforms to standards IEC/EN60947-4-1

2. Type designation

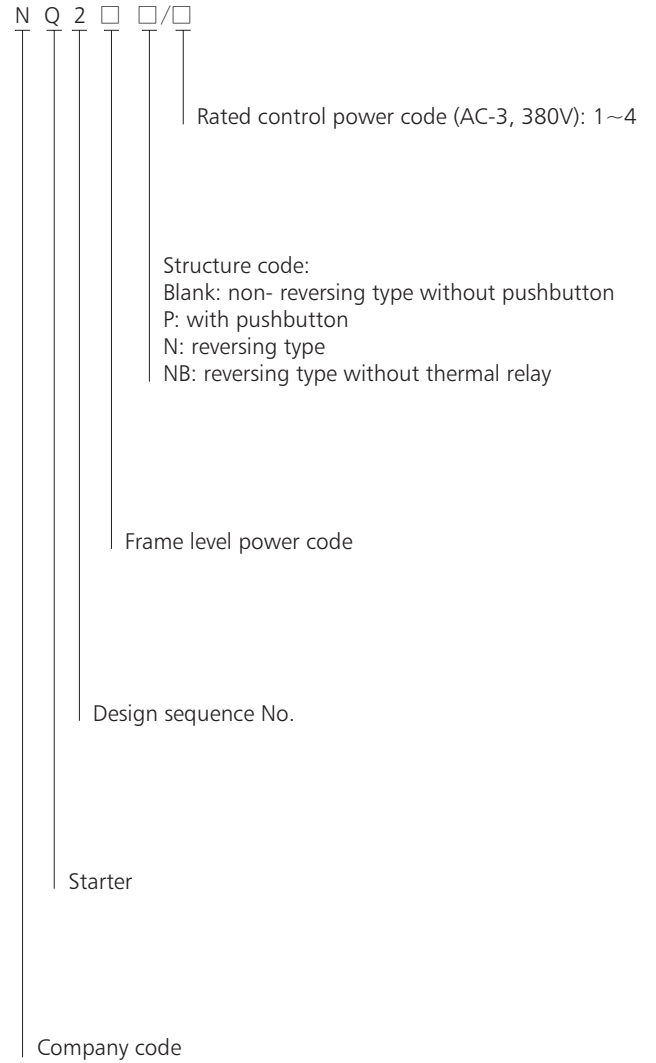

3. Technical data

3.1 NQ2-15, 33

Model	Conventional heating current I _{th} (A)	Rated operational current I _e (A)	Rated power (AC-3)			Model of matched contactor	Model of matched relay	Range of setting current (A)
			(kW)					
			660V	380V	220V			
NQ2-15/1	13	12	7.5	5.5	3	NC1-1210	NR2-25	0.1~0.16
								0.16~0.25
								0.25~0.4
								0.63~1
								1~1.6
								1.25~2
								1.6~2.5
								2.5~4
NQ2-15/2	18	18	10	7.5	4	NC1-1810	NR2-25	7~10
								9~13
NQ2-15/3	25	25	15	11	5.5	NC1-2510	NR2-25	12~18
NQ2-15/4	36	32	18.5	15	7.5	NC1-3210	NR2-36	17~25
								23~32
NQ2-33/1	52	52	33	25	15	NC1-6511	NR2-93	28~36
								23~32
								30~40
NQ2-33/2	68	68	37	33	25	NC1-9511	NR2-93	37~50
								48~65
								55~70
								63~80

3.2 NQ2-15P, 33P

Model	Conventional heating current I _{th} (A)	Rated operational current I _e (A)	Rated power (AC-3)			Model of matched contactor	Model of matched relay	Model of matched pushbutton	Range of setting current (A)
			(kW)						
			660V	380V	220V				
NQ2-15P/1	13	12	7.5	5.5	3	NC1-1210	NR2-25	Start: NP2-EA31 Stop: NP2-EA42	0.1~0.16
									0.16~0.25
									0.25~0.4
									0.63~1
									1~1.6
									1.25~2
									1.6~2.5
									2.5~4
NQ2-15P/2	18	18	10	7.5	4	NC1-1810	NR2-25	NP2-EA42	4~6
									5.5~8
NQ2-15P/3	25	25	15	11	5.5	NC1-2510	NR2-25	7~10	
NQ2-15P/4	36	32	18.5	15	7.5	NC1-3210	NR2-36	NP2-EA42	9~13
									12~18
NQ2-33P/1	52	52	33	25	15	NC1-6511	NR2-93	NP2-EA42	17~25
									23~32
									28~36
NQ2-33P/2	68	68	37	33	25	NC1-9511	NR2-93	NP2-EA42	23~32
									30~40
									37~50
									48~65
									55~70
									63~80

3.3 NQ2-15 N

Model	Conventional heating current I _{th} (A)	Rated operational current I _e (A)	Rated power (AC-3)			Model of matched contactor	Model of matched relay	Range of setting current (A)
			(kW)					
			660V	380V	220V			
NQ2-15N/1	13	12	7.5	5.5	3	NC1-1210	NR2-25	0.1~0.16 0.16~0.25 0.25~0.4 0.63~1 1~1.6 1.25~2 1.6~2.5 2.5~4 4~6 5.5~8 7~10 9~13 12~18
NQ2-15N/2	18	18	10	7.5	4	NC1-1810	NR2-25	17~25
NQ2-15N/3	25	25	15	11	5.5	NC1-2510		23~32
NQ2-15N/4	36	32	18.5	15	7.5	NC1-3210	NR2-36	28~36

3.4 NQ2-15NB

Model	Conventional heating current I _{th} (A)	Rated operational current I _e (A)	Rated power (AC-3)			Model of matched contactor
			(kW)			
			660V	380V	220V	
NQ2-15NB/1	13	12	7.5	5.5	3	NC1-1201N
NQ2-15NB/2	18	18	10	7.5	4	NC1-1801N
NQ2-15NB/3	25	25	15	11	5.5	NC1-2501N
NQ2-15NB/4	36	32	18.5	15	7.5	NC1-3201N

Altitude: not exceeding 2000m; Temperature of ambient air: -5°C~+40°C
 Rated control supply voltage (AC 50Hz): 24V, 36V, 48V, 110V, 127V, 220V, 380V, 415V
 Mechanical life: 1,000,000 circles; Electric life: 500,000 circles; IP40

4. Overall and mounting dimensions (mm)

NQ2-15

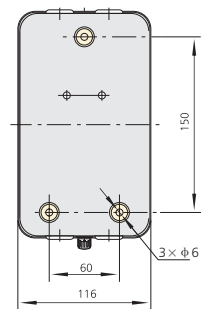
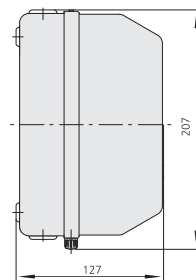

NQ2-15P

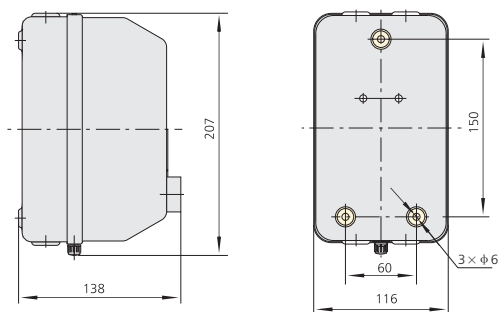
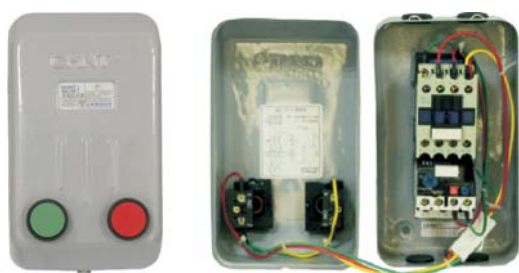

NQ2-15N

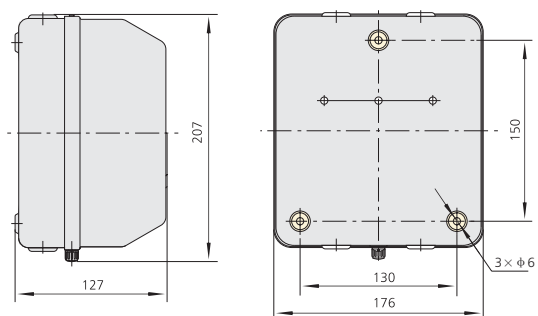

NQ2-15NB

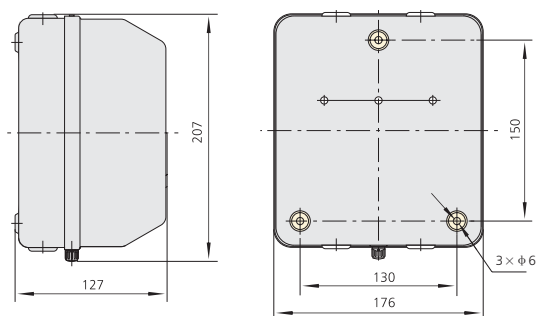

NQ2-33

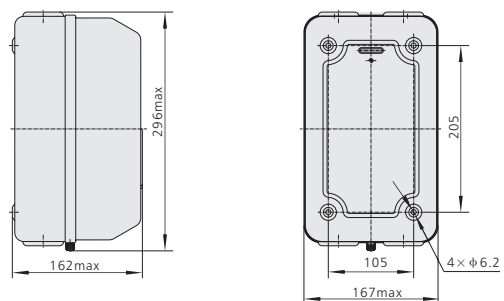

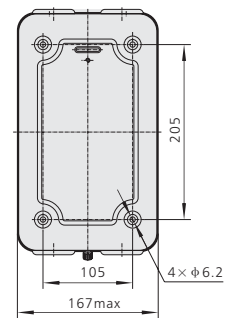
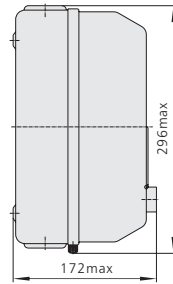

5. Wiring Diagram

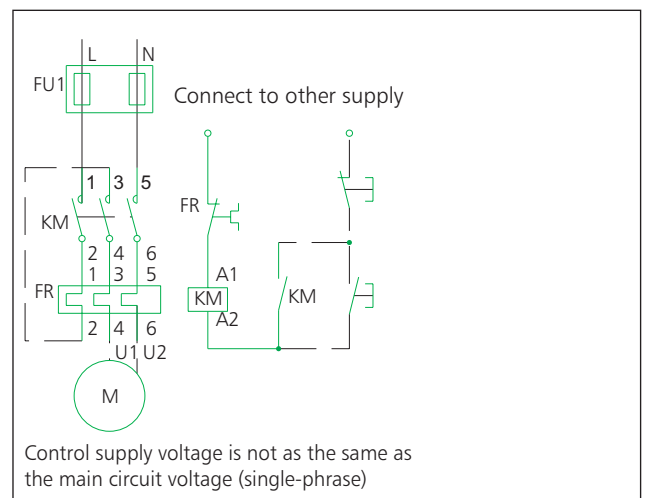
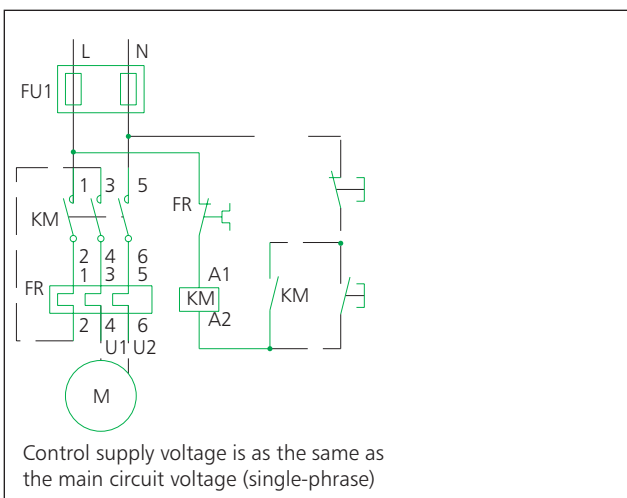
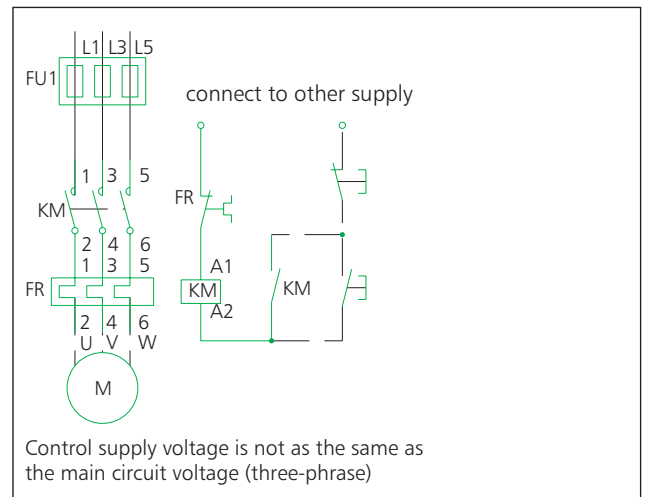
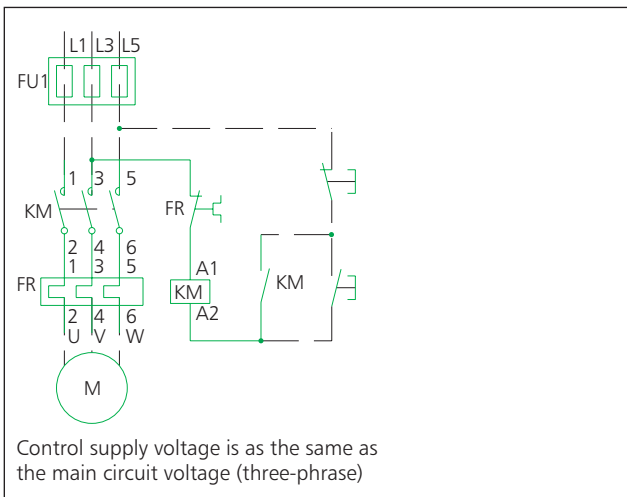



NQ3 DOL Electromagnetic Starter

1. General

- 1.1 NQ3 series electromagnetic starter ("starter" for short hereinafter) applies mainly to circuit with AC current of 50Hz (or 60Hz), rated operational voltage of 660V and rated controlled power up to 11kW (current up to 22A) for using to control the direct start and halt of the electromotor to protect the motor from overload and phase failure.
- 1.2 The starter conforms to standards IEC/EN60947-4-1

2. Type designation

N Q 3 - □ P

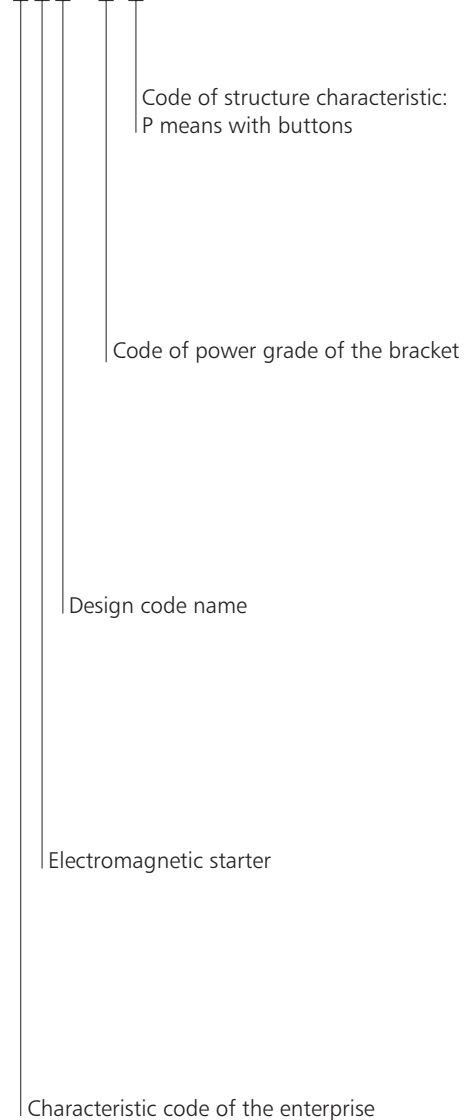

3. Technical data

- Altitude: not exceeding 2000m;
- Temperature of ambient air: -5°C~+40°C
- Rated control supply voltage (AC 50Hz): 24V, 36V, 48V, 110V, 127V, 220V, 380V, 415V
- Mechanical life: 1,000,000 circles;
- Electric life: 500,000 circles;
- IP55

Table 1 Basic Model and main technical parameter of the starter

Model	Rated working current (A)	Maximum rated Power (kW)			Model of equipped AC contactor	TOR matched	Range of setting current A
		AC-3					
		660V	380V	220V			
NQ3-5.5P	12	7.5	5.5	3	NC1-1810	NR2-25	0.1~0.16
							0.16~0.25
							0.25~0.4
							0.4~0.63
							0.63~1
							1~1.6
							1.25~2
							1.6~2.5
							2.5~4
							4~6
NQ3-11P	22	15	11	5.5	NC1-3210		9~13
							12~18
							17~25

4. Overall and mounting dimension (mm)

NQ3-5.5P

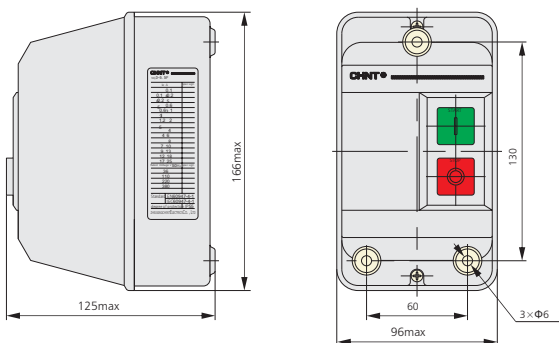

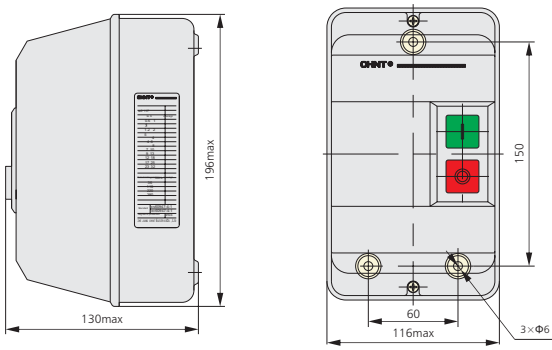

5. Wiring Diagram

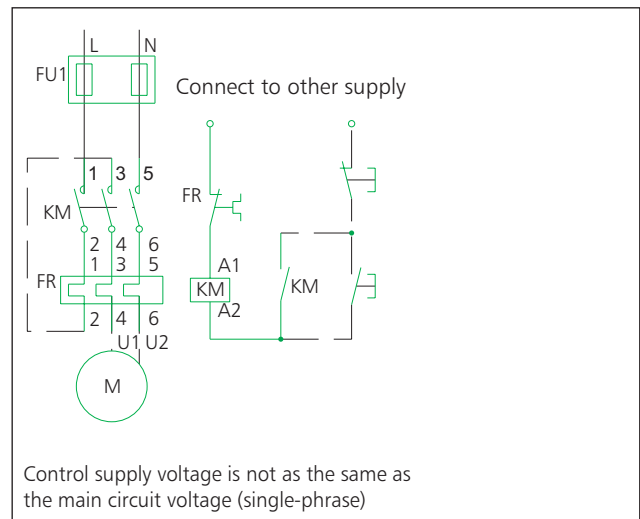
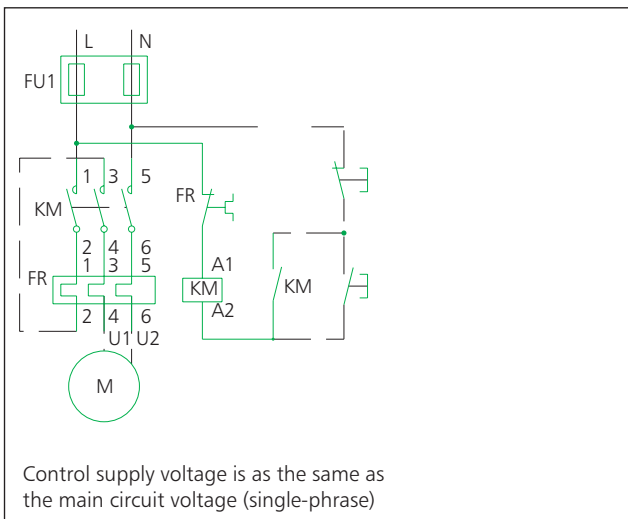
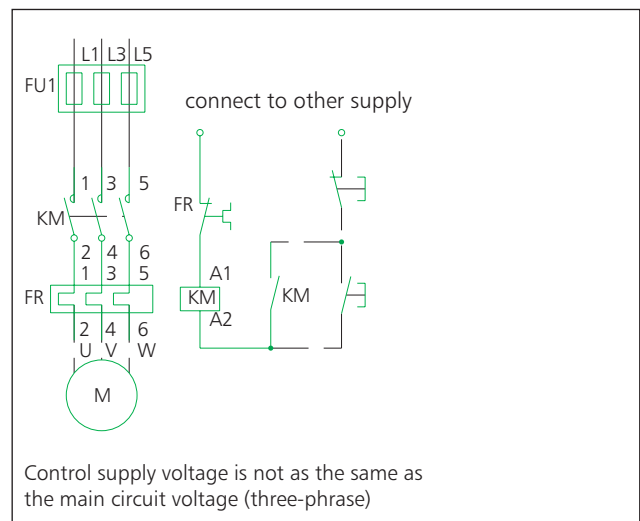
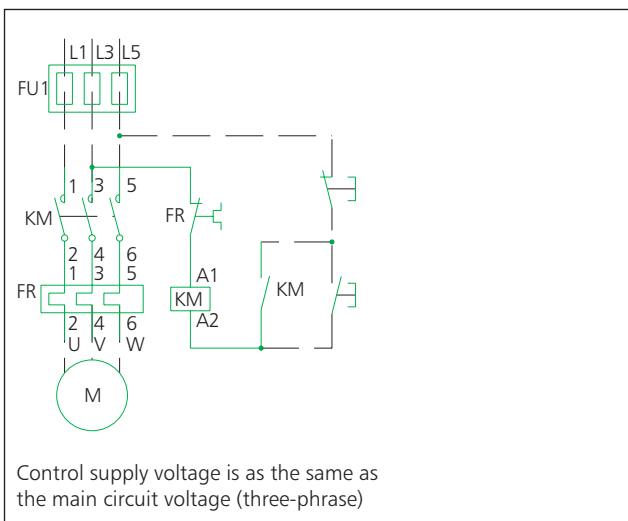

6. Picture

NQ3-5.5P



NQ3-11P

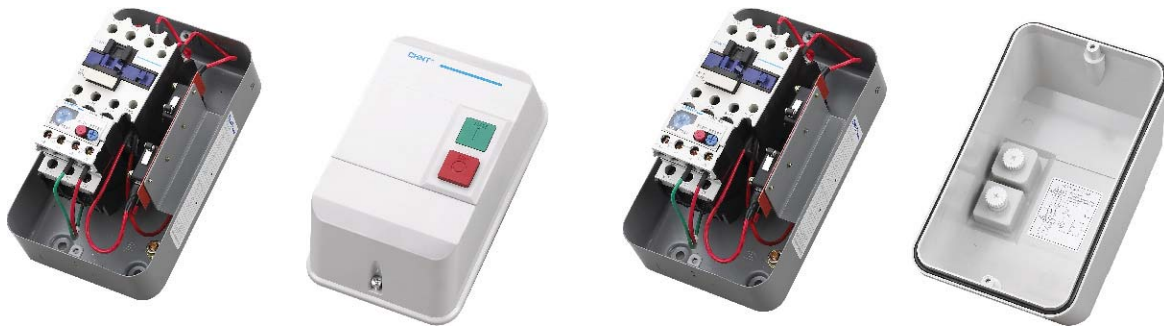

F